

Specifications

Output Power HP (kW)	10 (7.5)
Phase	3 Phase
Pole	2 Pole
Frame Number	132S

Degrees of Protection	IP 55
Enclosure Construction	Totally-enclosed Fan-cooled
Thermal Class	Class F (155 °C)

Alignment	Vertical
Frame Material	Steel plate

Power Transmission	Direct-couple or Belt Driven
Direction of Rotation	Counterclockwise (CCW) viewed from shaft-end side

Connection Type	Terminal Block (6 Leads)
Coating Colour	Munsell N5.5 (Gray)
Conformed Standard	IEC 60034-1 & JEC-2137-2000

Voltage & Frequency	HT Type
	380~415V 50Hz 380~440V 60Hz (suitable for Y-Δ starting)

Dimensions (mm)

Flange Number	Motor								
	D	IE	LA	LB	LC	LE	LG	LL	LZ
FF265	266	156	265	230 j6	300	4	20	392.5	14.5

Terminal Box			Shaft End						
KD	KG	KL	LR	Q	QK	S	T	U	W
PF 1	173	213	80	80	63	38 k6	8	5	10

Bearing No.		Approximated Weight (kg)	Approximated Packing Dimensions (LxWxH)	Gross Weight (kg)
Drive End	Opposite			
6308ZZ	6207ZZ	63	569 x 459 x 386	71

Connection & Connection Diagram

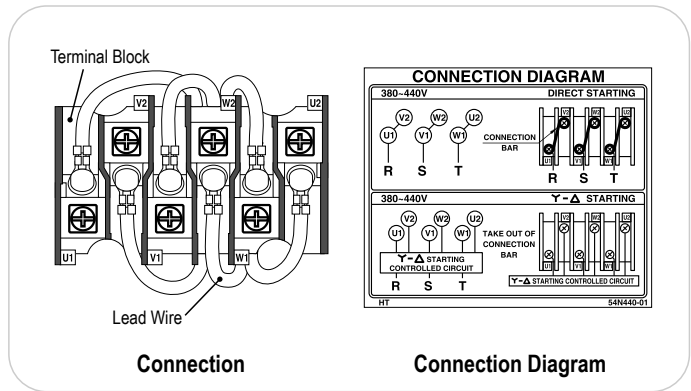

Circumstance Conditions

Ambient Temperature	-20 ~ +40°C
Ambient Humidity	95% RH or less
Operating Altitude	Less than 1,000m above sea level
Environment	No bursting / erosive gas or vapor

Motor Characteristics

Type	Hz	V	50% Load			75% Load			100% Load				Torque(%)		Is (A)	Inertia GD ² (kg-m ²)	
			(A)	Eff(%)	PF(%)	(A)	Eff(%)	PF(%)	(A)	Eff(%)	PF(%)	Speed (r/min)	Torque (kg-m)	Ts			Tm
HT	50	380	7.89	0.90	0.80	10.8	0.91	0.87	14.1	0.91	0.89	2900	2.51	227	274	99.8	0.066
		415	8.23	0.89	0.71	10.7	0.91	0.80	13.5	0.91	0.85	2920	2.50	273	326	109	
	60	380	7.4	0.88	0.87	10.5	0.90	0.90	13.9	0.90	0.91	3480	2.09	180	234	84.8	
		440	7.07	0.87	0.80	9.52	0.90	0.86	12.2	0.91	0.89	3510	2.08	244	316	98.5	